

SPECIFICATION SHEET: S022

SYSTEM 3000 CHANGING ROOM FURNITURE

Single-Sided Unit

System 3100 Standard
System 3200 Humidity Resistant

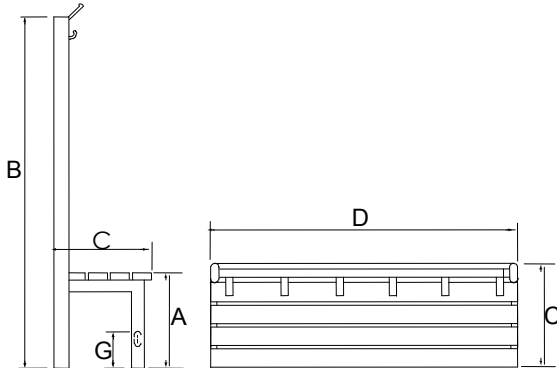

Dimensions

A	450 mm
B	1700 mm
C	460 mm
D	1500 mm
E	660 mm
F	380 mm
G	150 mm

The standard width of the unit (D) is 1.5 m. Units to specific lengths are available.

All units supplied in flat pack for assembly on site by customer.

Double-Sided Unit

System 3300 Standard
System 3400 Humidity Resistant

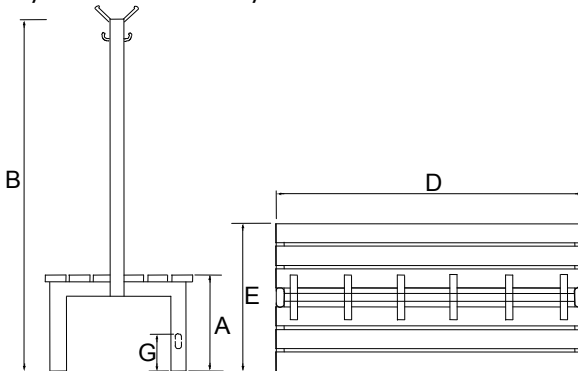

Wall Mounted Coat Hook Unit

System 3700 Standard
System 3800 Humidity Resistant

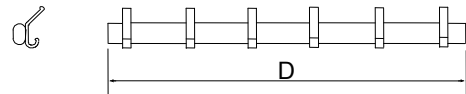

Wall/Island Seating Unit

System 3500 Standard
System 3600 Humidity Resistant

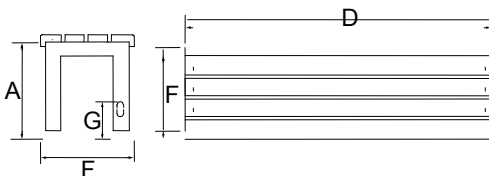

Key Features

Sturdy Construction	Welded frame to ensure strength and durability.
Style	Attractive oval section frame.
Floor Fixing Options	All units provided with adjustable height facility and floor fixing options.
Humidity Resistant	Option available – tested to BS7479

Detailed Product Specification (Dry Area) – See Optional Extras for Humidity Resistant Specification

Materials and Finish:

Frames:	Flat sided oval rolled hollowed section mild steel.
Seating:	Laminate or Durawood extruded Polymer, profiled front edge. Grey NCS 5000.
Coat Hooks:	Aluminium extrusion (epoxy powder coated). Grey NCS 5000.
Floor Fixing:	All seating units are supplied with the following fittings: Plastic bungs, hidden floor fixing brackets, adjustable foot and combination of floor fixing and adjustable foot.
Fixing side by side:	Special top bracket supplied for joining units together into runs (it is recommended the floor fixing facility is also used).

Optional Extras:

Hardwood Seating Slats:	The wood is grown specifically for furniture production and is produced by environmentally friendly procedures.
Humidity Resistance:	Zinc plated and passivated prior to finishing with Plascoat PPA571, offering a water-resistant coating for use in high humidity and water splashing areas. Tested to BS7479.
Colours:	Frame finished, epoxy powder coated. Fire Red RAL 3000 Sky Blue RAL 5015 Silver Grey RAL 7001 Moss Green RAL 6005
Installation:	We offers a full installation service for its products.

After Sales Service: All of our products are supported by the Service Department who provide technical advice, maintenance schemes, prompt delivery of replacement keys/parts and product refurbishment.

- Health & Safety: It is recommended that the products referred to in the specification sheet are fixed to the floor securely in accordance with the instructions provided with the product.
- All dimensions are nominal.
- To enable us to interpret your requirements accurately please state at time of order: Type of units required, Dimensions, Colour and Delivery requirements.
- The products described in this specification sheet herein are the subjects of patent, trademark, design and copyright protection or application thereof.
- In the interest of efficiency and service to our customers, the company reserves the right to modify the specifications of any of its products.